

NPN D 系列晶体管/D SERIES TRANSISTORS

BLD112D

- 特点: 耐压高 开关速度快 安全工作区宽 符合 RoHS 规范
- **FEATURES:** ■HIGH VOLTAGE CAPABILITY ■HIGH SPEED SWITCHING ■WIDE SOA ■RoHS COMPLIANT
- 应用: 节能灯 电子镇流器
- **APPLICATION:** ■FLUORESCENT LAMP ■ELECTRONIC BALLAST

- 最大额定值 (Tc=25°C)
- **Absolute Maximum Ratings (Tc=25°C) TO-92/92S/126/126S**

参数 PARAMETER	符号 SYMBOL	额定值 VALUE	单位 UNIT
集电极-基极电压 Collector-Base Voltage	V _{CB0}	600	V
集电极-发射极电压 Collector-Emitter Voltage	V _{CEO}	400	V
发射极-基极电压 Emitter-Base Voltage	V _{EBO}	9	V
集电极电流 Collector Current	I _c	1.0	A
集电极耗散功率 Total Power Dissipation	P _{tot}	TO-92/92S: 12	W
		TO-126/126S: 20	
最高工作温度 Junction Temperature	T _j	150	°C
贮存温度 Storage Temperature	T _{stg}	-65-150	°C

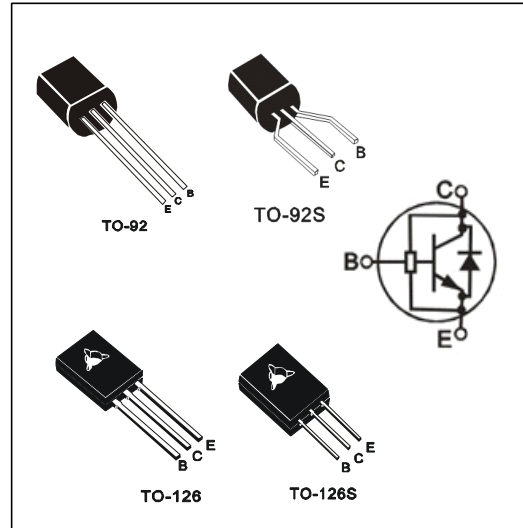

- 电特性 (Tc=25°C)
- **Electronic Characteristics (Tc=25°C)**

参数名称 CHARACTERISTICS	符号 SYMBOL	测试条件 TEST CONDITION	最小值 MIN	最大值 MAX	单位 UNIT
集电极-基极截止电流 Collector-Base Cutoff Current	I _{CB0}	V _{CB} =600V		100	μA
集电极-发射极截止电流 Collector-Emitter Cutoff Current	I _{CEO}	V _{CE} =400V, I _B =0		250	μA
集电极-基极电压 Collector-Base Voltage	V _{CB0}	I _C =1mA, I _E =0	600		V
集电极-发射极电压 Collector-Emitter Voltage	V _{CEO}	I _C =10mA, I _B =0	400		V
发射极-基极电压 Emitter-Base Voltage	V _{EBO}	I _E =1mA, I _C =0	9		V
集电极-发射极饱和电压 Collector-Emitter Saturation Voltage	V _{cesat}	I _C =200mA, I _B =40mA		0.2	V
		I _C =750mA, I _B =250mA		0.5	
发射极-基极饱和电压 Base-Emitter Saturation Voltage	V _{besat}	I _C =200mA, I _B =40mA		1.2	V
电流放大倍数 DC Current Gain	h _{FE}	V _{CE} =5V, I _C =1mA	7		
		V _{CE} =5V, I _C =0.1A	10	40	
		V _{CE} =5V, I _C =1A	5		
贮存时间/Storage Time	t _s	V _{CC} =5V, I _C =0.25A, (UI9600)	1.0	3.0	μs
下降时间/Falling Time	t _f			1.0	
内置二极管正向压降 Diode Forward Voltage	V _F	I _F =0.6A		2.0	V

● **订单信息/ORDERING INFORMATION:**

包装形式/PACKING	订货编码/ORDERING CODE	
	普通塑封料/ Normal Package Material	无卤塑封料/Halogen Free
TO-92 普通袋装/NORMAL PACKING	BLD112D TO-92	BLD112D TO-92-HF
TO-92S 普通袋装/NORMAL PACKING	BLD112D TO-92S	BLD112D TO-92S-HF
TO-92 盒式编带/AMMOPACK	BLD112D TO-92-AP	BLD112D TO-92-AP-HF
TO-126 普通袋装/NORMAL PACKING	BLD112D TO-126	BLD112D TO-126-HF
TO-126S 普通袋装/NORMAL PACKING	BLD112D TO-126S	BLD112D TO-126S-HF

NPN D 系列晶体管 / D SERIES TRANSISTORS

BLD112D

SOA (DC)

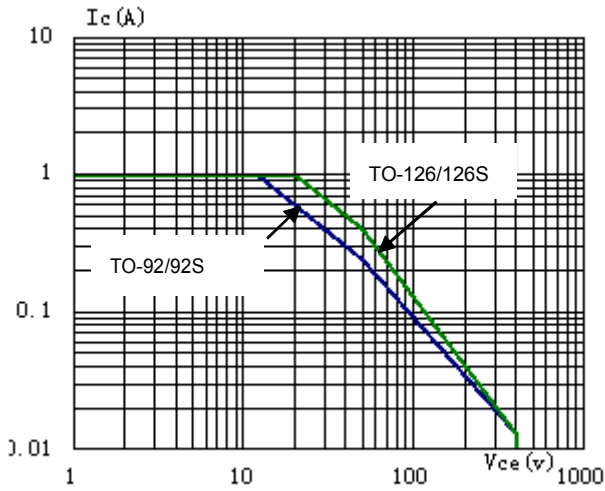

$P_{tot} \propto T_j$

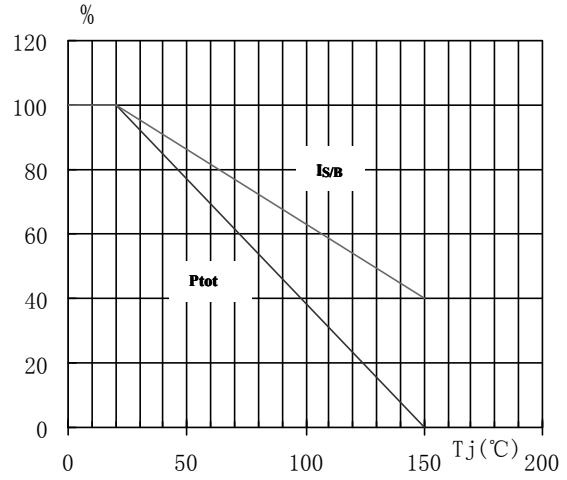

$h_{FE} - I_c$

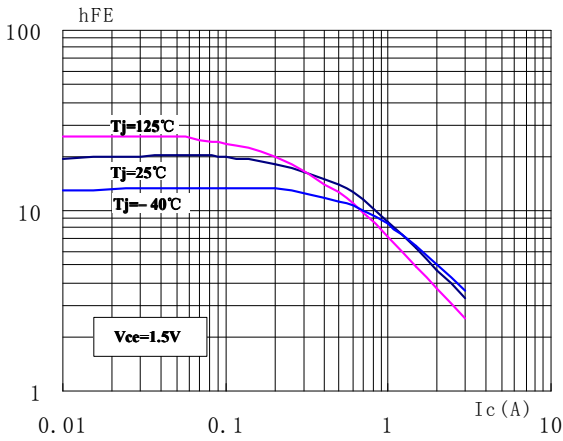

$h_{FE} - I_c$

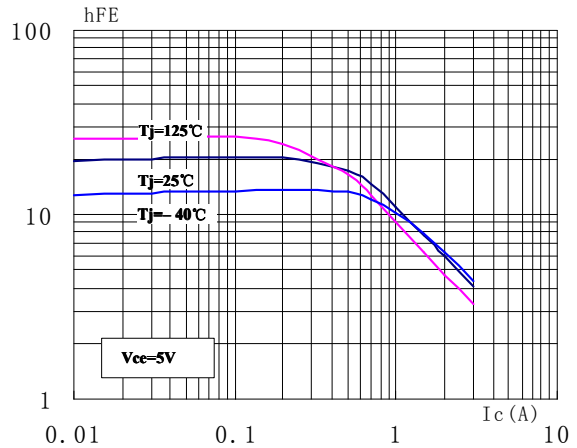

$V_{ces} - I_c$

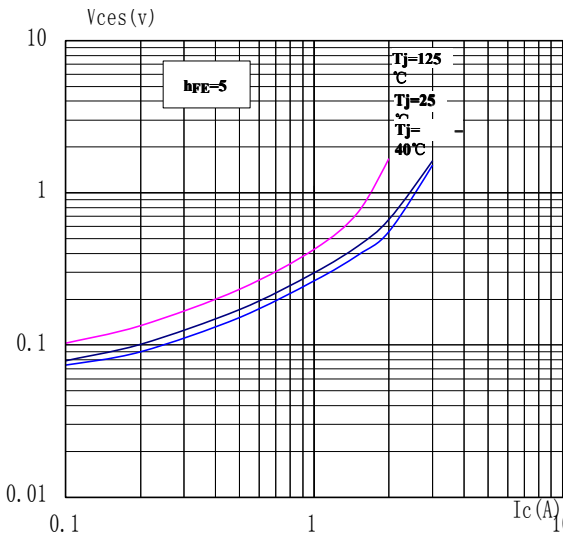

$V_{bes} - I_c$

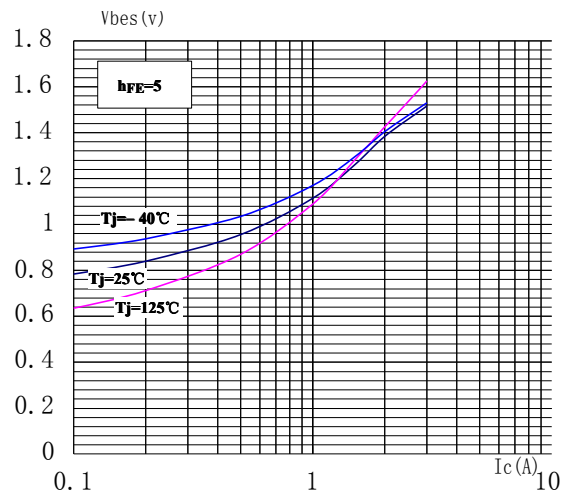

TO-92 封装机械尺寸 TO-92 MECHANICAL DATA

单位:毫米/UNIT: mm

符号/SYMBOL	最小值/min	典型值/nom	最大值/max
A	4.30		5.30
b	0.30		0.55
c	0.30		0.50
φD D	4.30		5.20
d	1.00		1.70
E	3.20		4.20
e		2.54	
e1		1.27	
L	12.70		15.00
L1	1.50		2.00

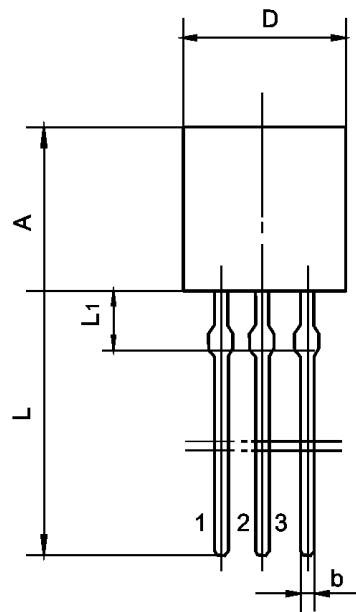
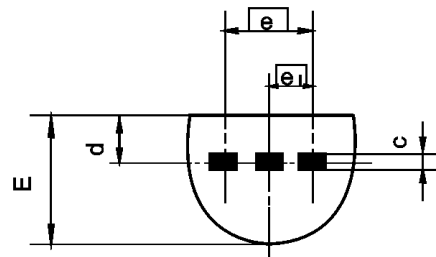

TO-92S 封装机械尺寸 TO-92S MECHANICAL DATA

单位:毫米/UNIT: mm

符号/SYMBOL	最小值/min	典型值/nom	最大值/max
A	4.30		5.30
b	0.30		0.55
c	0.30		0.50
D(ϕ D)	4.30		5.20
d	1.00		1.70
E	3.20		4.20
F	2.25	2.40	2.55
L	3.20		3.80
L1	2.60		2.70

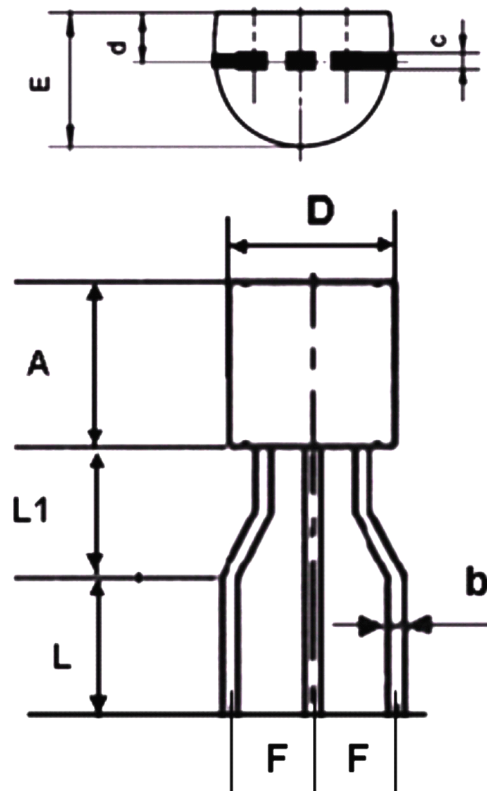

TO-92-AP 编带规格尺寸 TO-92 AMMOPACK DATA

单位:毫米/UNIT: mm

符号 SYMBOL	最小值 min	典型值 nom	最大值 max	符号 SYMBOL	最小值 min	典型值 nom	最大值 max
A	4.30		5.30	d	0.30		0.55
A1	4.30		5.20	T	3.20		4.20
DO	3.80	4.00	4.20	β	-	-	2° 10'
F1/F2	2.25	2.40	2.55	l1	2.50		
P	11.70	12.70	13.70	L1			11.00
PO	12.40	12.70	13.00	W	17.50	18.00	19.00
P2	5.95	6.35	6.75	W0	5.70	6.00	6.30
H	18.35		19.45	W1	8.50	9.00	9.75
H0	15.50	16.00	16.50	W2			0.50
H1			24.50	Δh	-1.00	0.00	1.00
H2	2.60		2.70	ΔP	-1.00	0.00	1.00
H3	9.50			t1	0.35		0.65
α	130°	135°	140°	t2			1.44

盒装量/BASE QUANTITY: 3000pcs/box

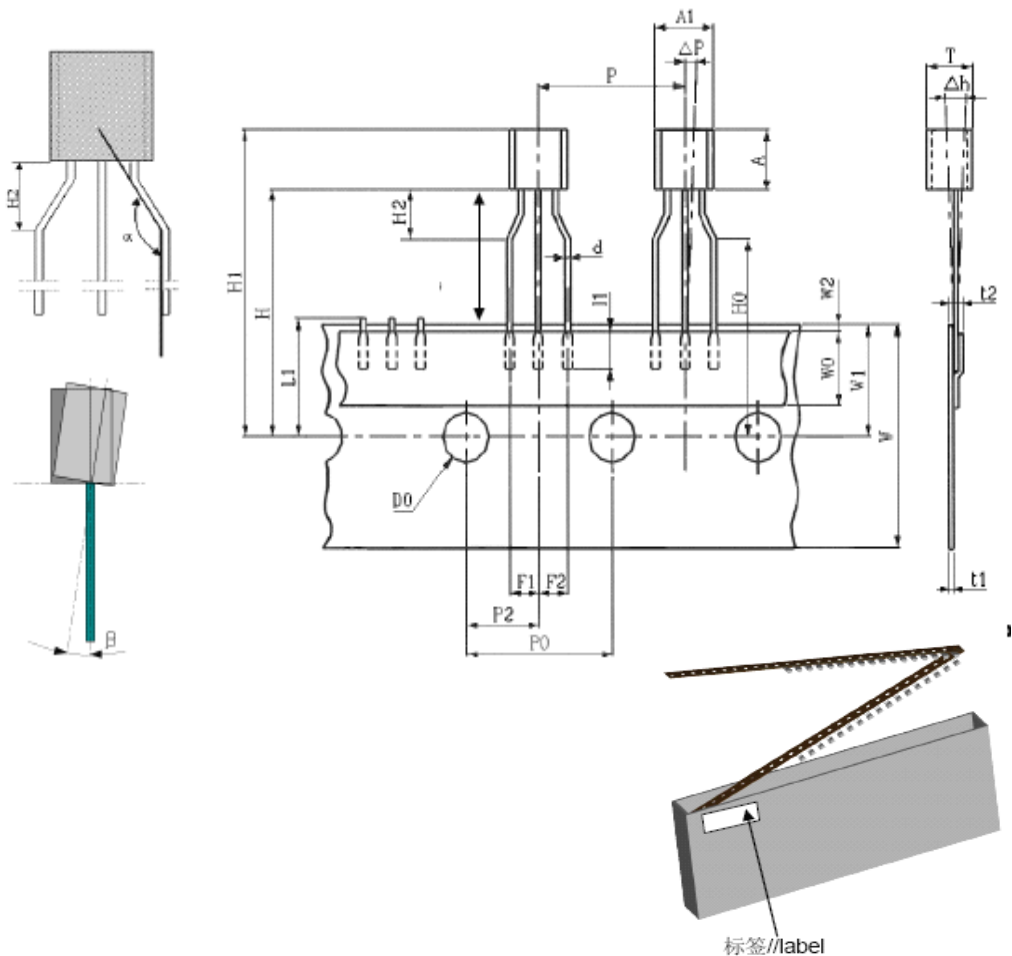

TO-126 封装机械尺寸 TO-126 MECHANICAL DATA

单位:毫米/UNIT: mm

符号 SYMBOL	最小值 min	典型值 nom	最大值 max	符号 SYMBOL	最小值 min	典型值 nom	最大值 max
A	2.30		2.80	L	15.00		16.50
B	1.15		1.42	L1	1.50		2.54
b	0.65		0.90	ϕP	2.90		3.60
c	0.35		0.65	$\phi P1$		5.00	
D	10.50		11.10	Q	3.60		4.40
E	7.20		7.80	Q1	0.90		1.50
e		2.29		R		0.50	

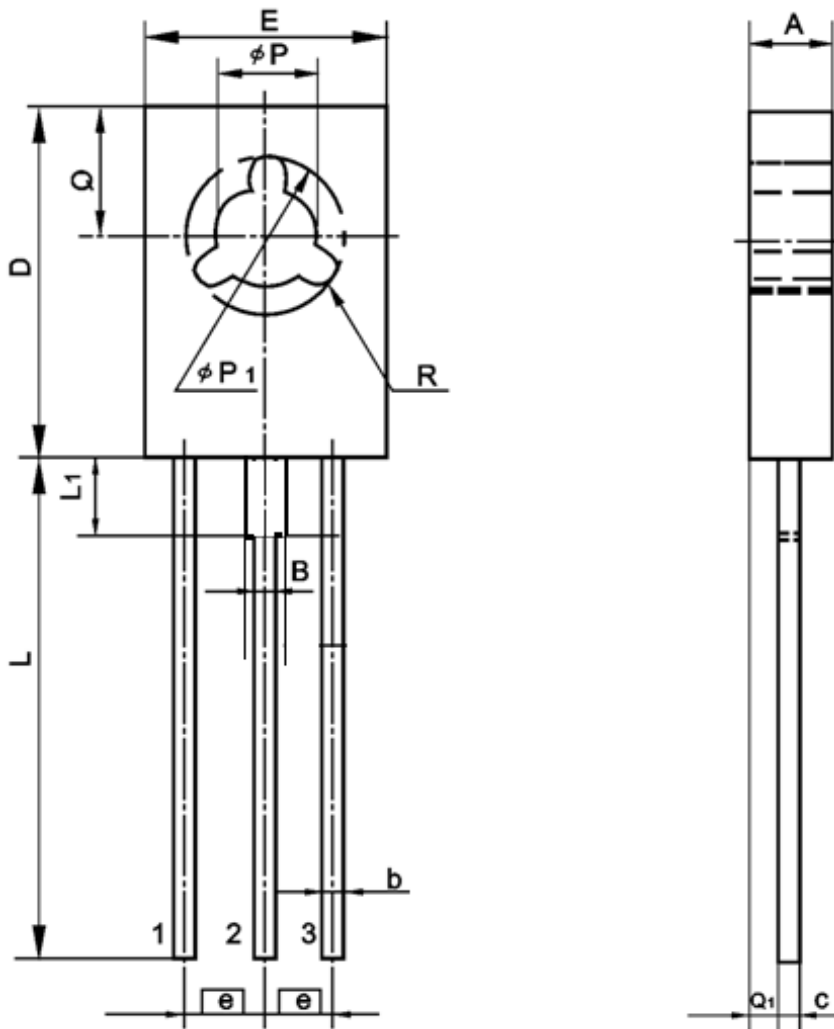

TO-126S 封装机械尺寸 TO-126S MECHANICAL DATA

单位:毫米/UNIT: mm

符号 SYMBOL	最小值 min	典型值 nom	最大值 max	符号 SYMBOL	最小值 min	典型值 nom	最大值 max
A	2.30		2.80	L	3.20		3.80
B	1.15		1.42	L1	1.50		2.54
b	0.65		0.90	ϕP	2.90		3.60
c	0.35		0.65	$\phi P1$		5.00	
D	10.50		11.10	Q	3.60		4.40
E	7.20		7.80	Q1	0.90		1.50
e		2.29		R		0.50	

