

**NPN D 系列晶体管/ D SERIES TRANSISTORS**

**BLD122DT**

- 特点: 耐压高 开关速度快 安全工作区宽 符合 RoHS 规范
- FEATURES: ■HIGH VOLTAGE CAPABILITY ■HIGH SPEED SWITCHING ■WIDE SOA ■RoHS COMPLIANT
- 应用: 电子镇流器 节能灯
- APPLICATIONS: ■ELECTRONIC BALLAST ■FLUORESCENT LAMP

●最大额定值 (Tc=25°C)

●Absolute Maximum Ratings (Tc=25°C) TO-251T/251S/252

参数 PARAMETER	符号 SYMBOL	额定值 VALUE	单位 UNIT
集电极-基极电压 Collector-Base Voltage	V <sub>CB0</sub>	800	V
集电极-发射极电压 Collector-Emitter Voltage	V <sub>CEO</sub>	450	V
发射极-基极电压 Emitter-Base Voltage	V <sub>EBO</sub>	9	V
集电极电流 Collector Current	I <sub>C</sub>	1.2	A
集电极耗散功率 Total Power Dissipation	P <sub>tot</sub>	25	W
最高工作温度 Junction Temperature	T <sub>j</sub>	150	°C
贮存温度 Storage Temperature	T <sub>stg</sub>	-65-150	°C

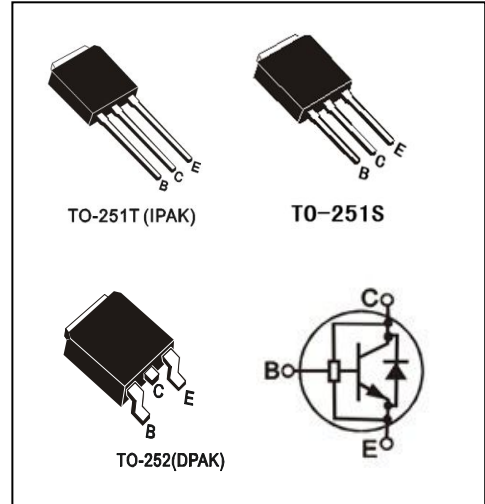

●电特性 (Tc=25°C)

●Electronic Characteristics (Tc=25°C)

参数 CHARACTERISTICS	符号 SYMBOL	测试条件 TEST CONDITION	最小值 MIN	最大值 MAX	单位 UNIT
集电极-基极截止电流 Collector-Base Cutoff Current	I <sub>CB0</sub>	V <sub>CB</sub> =800V		100	μA
集电极-发射极截止电流 Collector-Emitter Cutoff Current	I <sub>CEO</sub>	V <sub>CE</sub> =450V, I <sub>B</sub> =0		250	μA
集电极-基极电压 Collector-Base Voltage	V <sub>CB0</sub>	I <sub>C</sub> =1mA, I <sub>E</sub> =0	800		V
集电极-发射极电压 Collector-Emitter Voltage	V <sub>CEO</sub>	I <sub>C</sub> =10mA, I <sub>B</sub> =0	450		V
发射极-基极电压 Emitter-Base Voltage	V <sub>EBO</sub>	I <sub>E</sub> =1mA, I <sub>C</sub> =0	9		V
集电极-发射极饱和电压 Collector-Emitter Saturation Voltage	V <sub>cesat</sub>	I <sub>C</sub> =0.5A, I <sub>B</sub> =0.1A		0.5	V
		I <sub>C</sub> =1A, I <sub>B</sub> =0.5A		0.6	
发射极-基极饱和电压 Base-Emitter Saturation Voltage	V <sub>bemat</sub>	I <sub>C</sub> =0.5A, I <sub>B</sub> =0.1A		1.2	V
电流放大倍数 DC Current Gain	h <sub>FE</sub>	V <sub>CE</sub> =5V, I <sub>C</sub> =1mA	7		
		V <sub>CE</sub> =10V, I <sub>C</sub> =0.1A	10	40	
		V <sub>CE</sub> =5V, I <sub>C</sub> =1.2A	5		
贮存时间/Storage Time	t <sub>s</sub>	V <sub>CC</sub> =5V, I <sub>C</sub> =0.25A (UI9600)	1.5	3.0	μs
下降时间/Falling Time	t <sub>f</sub>			0.8	
内置二极管正向压降 Diode Forward Voltage	V <sub>F</sub>	I <sub>F</sub> =1.0A		2.6	V

●订单信息/ORDERING INFORMATION:

包装形式/PACKING	订货编码/ORDERING CODE	
	普通塑封料 Normal Package Material	无卤塑封料 Halogen Free
TO-251T 或 251S 或 252 普通袋装/NORMAL PACKING	BLD122DT TO-251T 或 251S 或 252	BLD122DT TO-251T-HF 或 TO-251S-HF 或 TO-252-HF
TO-251T 或 251S 或 252 条管装/TUBE PACKING	BLD122DT TO-251T 或 251S-TU 或 252-TU	BLD122DT TO-251T 或 TO-251S 或 TO-252-TU-HF
TO-252 盘式编带/TAPE&REEL PACKING	BLD122DT TO-252-TR	BLD122DT TO252-TR-HF

NPN D 系列晶体管 / D SERIES TRANSISTORS

BLD122DT

SOA (DC)

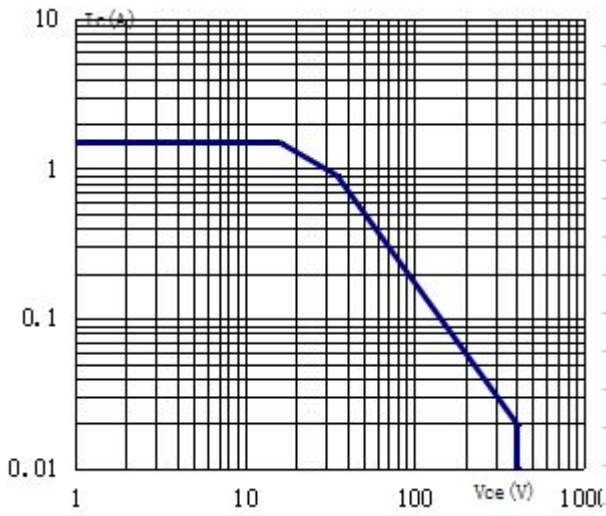

$P_{tot} \propto T_j$

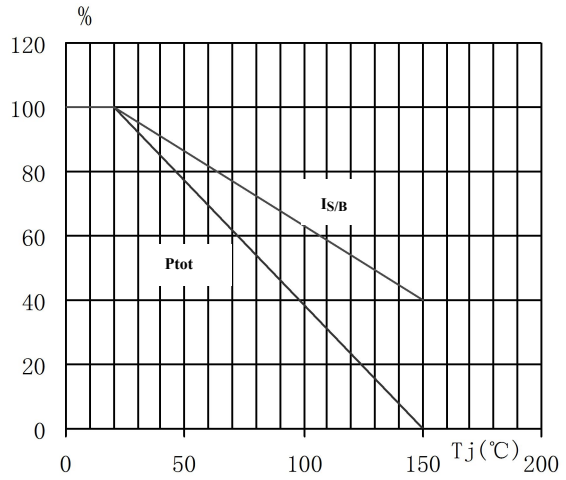

$h_{FE} - I_c$

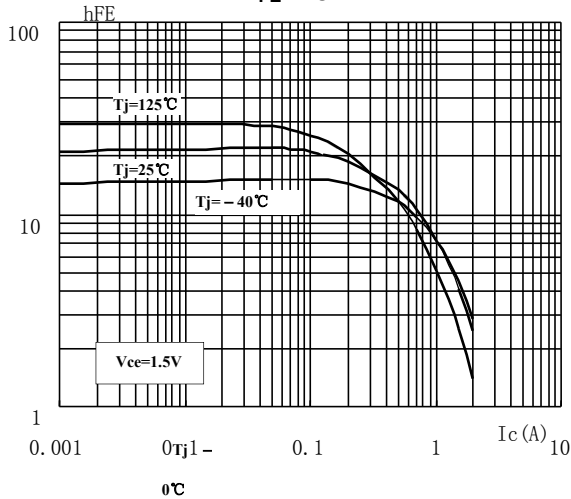

$h_{FE} - I_c$

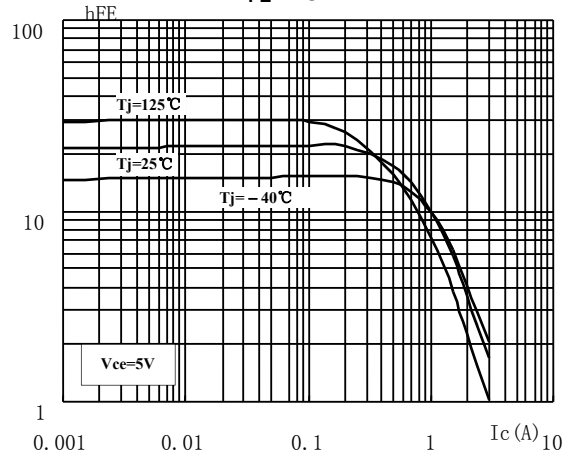

$V_{cesat} - I_c$

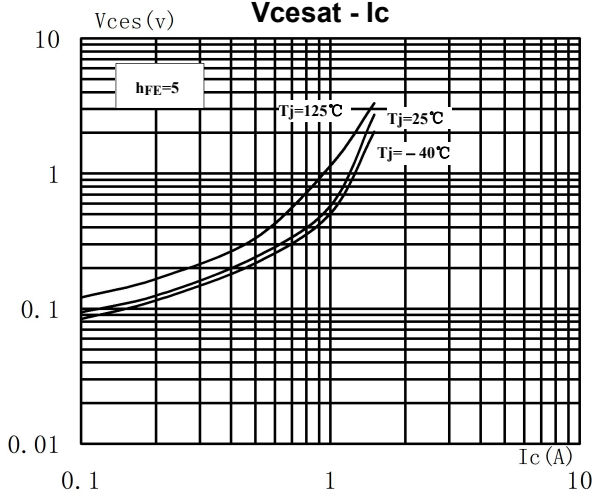

$V_{besat} - I_c$

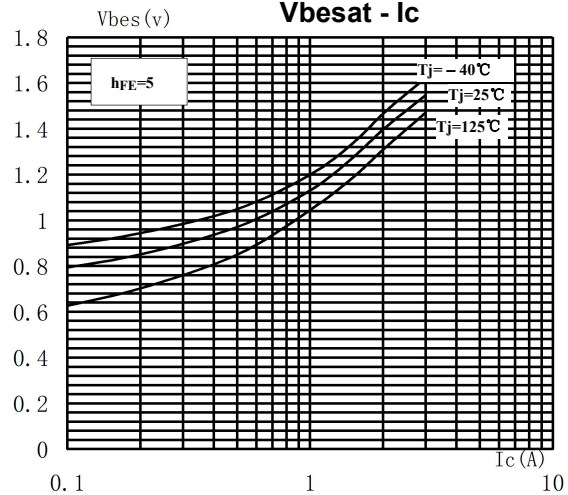

## TO-251T 封装机械尺寸 TO-251T (IPAK) MECHANICAL DATA

单位:毫米/UNIT: mm

符号/SYMBOL	最小值/min	典型值/nom	最大值/max
A	2.10		2.50
A <sub>1</sub>	0.95		1.30
B	0.80		1.25
b	0.50		0.80
b <sub>1</sub>	0.70		0.80
c	0.45		0.70
c <sub>1</sub>	0.45		0.70
D	6.35		6.80
D <sub>1</sub>	5.10		5.50
E	5.30		6.30
e	2.25	2.30	2.35
L	7.00		9.20
H	0.35		0.45
W1	0.30		0.50
W2	0.20		0.40

[S/L]

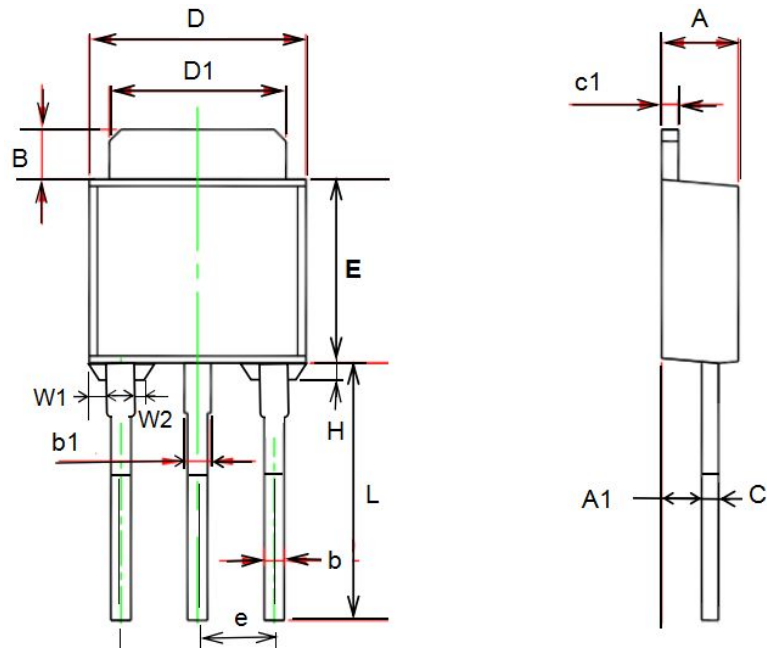

## TO-251S 封装机械尺寸 TO-251S (IPAK) MECHANICAL DATA

单位:毫米/UNIT: mm

符号/SYMBOL	最小值/min	典型值/nom	最大值/max
A	2.20		2.40
b	0.50		0.85
C	0.45	0.50	0.60
D	6.50		6.70
D1	5.10		5.50
E	5.9		6.20
e	2.18	2.29	2.38
L	11.00		12.40
L1	4.8		5.3
L2	3.5		4.2

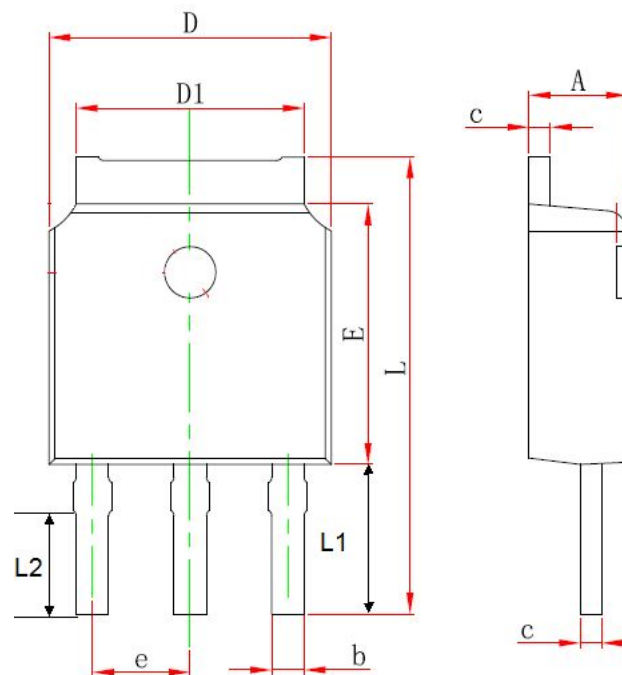

## TO-252 封装机械尺寸 TO-252 MECHANICAL DATA

单位:毫米/UNIT: mm

符号 SYMBOL	最小值 min	最大值 max	符号 SYMBOL	最小值 min	最大值 max
A	2.10	2.50	B	0.85	1.25
b	0.50	0.80	<b>b1</b>	<b>0.70</b>	<b>1.20</b>
b2	0.45	0.70	C	0.45	0.70
D	6.30	6.75	D1	5.10	5.50
E	5.30	6.30	e1	2.25	2.35
L1	9.20	10.60	e2	4.45	4.75
L2	0.90	1.75	L3	0.60	1.10
K	0.00	0.23			

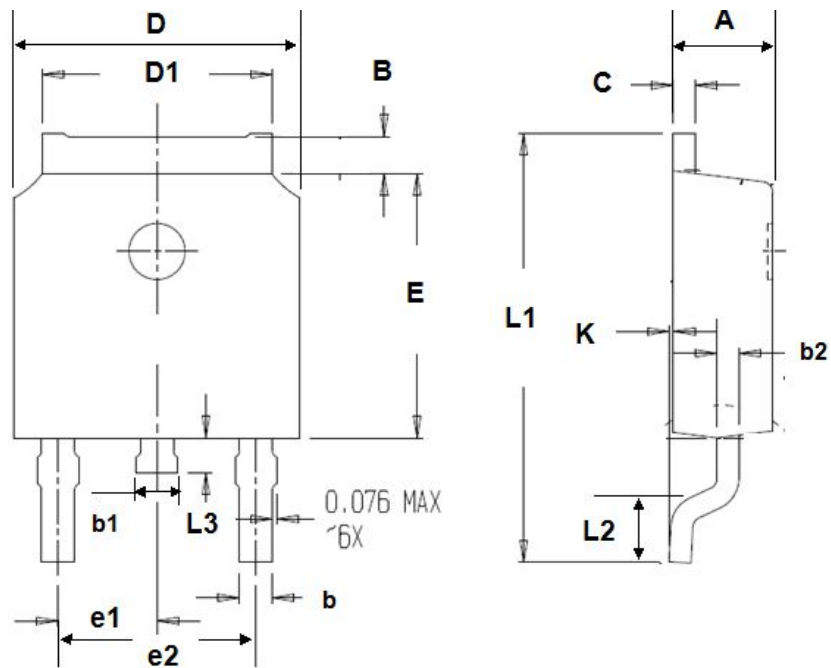

## TO-252 编带规格尺寸 TO-252 TAPE AND REEL DATA

单位:毫米/UNIT: mm

符号 SYMBOL	最小值 min	典型值 nom	最大值 max	符号 SYMBOL	最小值 min	典型值 nom	最大值 max
A0	6.80	6.90	7.00	B0	10.40	10.50	10.60
K0	2.60	2.70	2.90	K1	2.40	2.50	2.60
F	7.40	7.50	7.60	K2	1.60	1.70	1.80
W	15.90	16.00	16.10	P1	7.90	8.00	8.10

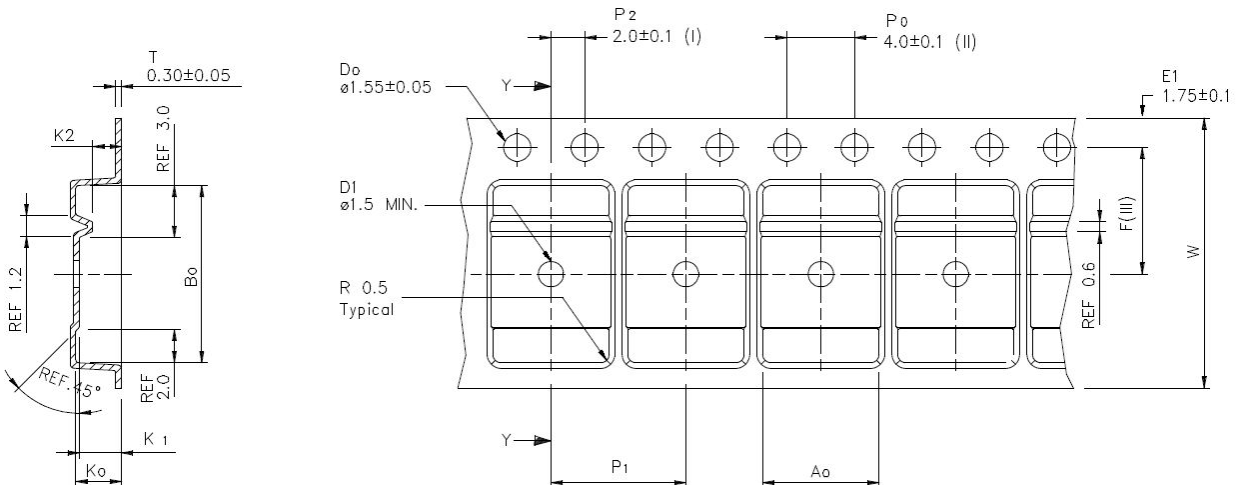

使用供带方向/USER DIRECTION OF FEED

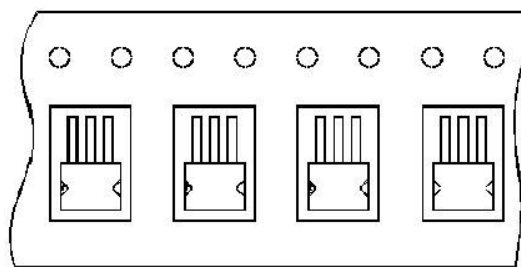

编带器件定位/UNIT ORIENTATION