

N-沟道功率 MOS 管/ N-CHANNEL POWER MOSFET

SIF60N030

- 特点：热阻低 导通电阻低 栅极电荷低，开关速度快 输入阻抗高 符合RoHS规范
- FEATURES: ■LOW THERMAL RESISTANCE ■LOW $R_{DS(ON)}$ TO MINIMIZE CONDUCTIVE LOSS ■LOW GATE CHARGE FOR FAST SWITCHING ■HIGH INPUT RESISTANCE ■RoHS COMPLIANT
- 应用：低压高频逆变电路 同步整流 开关应用
- APPLICATION: ■LOW VOLTAGE,HIGH FREQUENCY INVERTERS ■SYNCHRONOUS RECTIFICATION ■SWITCH APPLICATIONS

●最大额定值 (TC=25°C)

●Absolute Maximum Ratings (Tc=25°C) DFN3*3-8L

参数 PARAMETER	符号 SYMBOL	额定值 VALUE	单位 UNIT
漏-源电压 Drain-source Voltage	V_{DS}	30	V
栅-源电压 gate-source Voltage	V_{GS}	±20	V
漏极电流 Continuous Drain Current TC=25°C	I_D	60	A
耗散功率 Total Power Dissipation	P_{tot}	46	W
最高结温 Junction Temperature	T_j	150	°C
存储温度 Storage Temperature	T_{STG}	-55-175	°C
单脉冲雪崩能量 Single Pulse Avalanche Energy ①	E_{AS}	100	mJ

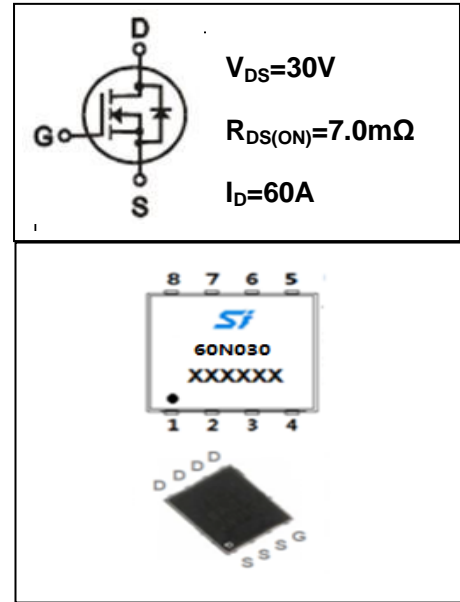

●电特性 (Tc=25°C)

●Electronic Characteristics (Tc=25°C)

参数 PARAMETER	符号 SYMBOL	测试条件 TEST CONDITION	最小值 MIN	典型值 TYP	最大值 MAX	单位 UNIT
漏-源击穿电压 Drain-source Breakdown Voltage	BV_{DSS}	$V_{GS}=0V, I_D=250\mu A$	30			V
栅极开启电压 Gate Threshold Voltage	$V_{GS(TH)}$	$V_{GS}=V_{DS}, I_D=250\mu A$	1.0		3.0	V
漏-源漏电流 Drain-source Leakage Current	I_{DSS}	$V_{DS}=30V, V_{GS}=0V$			1	μA
栅极漏电流 Gate-body Leakage Current ($V_{DS}=0$)	I_{GSS}	$V_{GS}=\pm 20V$			±100	nA
漏-源导通电阻 Static Drain-source On Resistance	$R_{DS(ON)}$	$V_{GS}=10V, I_D=30A$		7	9	mΩ
		$V_{GS}=4.5V, I_D=20A$		8.5	11	
跨导 Forward Transconductance	g_{FS}	$V_{DS}=10V, I_D=30A$		38		S

●订单信息/ORDERING INFORMATION:

包装形式/PACKING	订货编码/ORDERING CODE	
	普通塑封料/ Normal Package Material	无卤塑封料/Halogen Free
DFN3x3 编带装/TAPE & REEL PACKING	SIF60N030 DFN3x3-TR	SIF60N030 DFN3x3-TR-HF

N-沟道功率 MOS 管/ N-CHANNEL POWER MOSFET

SIF60N030

参数 PARAMETER	符号 SYMBOL	测试条件 TEST CONDITION	最小值 MIN	典型值 TYP	最大值 MAX	单位 UNIT
输入电容 Input Capacitance	Ciss	$V_{GS} = 0V, V_{DS} = 15V$ $F = 1.0MHz$		1317		pF
输出电容 Output Capacitance	Coss			163		
反向传输电容 Reverse Transfer Capacitance	Crss			130		
导通延迟 Turn -On Delay Time	Td(on)	$V_{DD}=15V, I_D =15A,$ $V_{GS} = 10V, R_G=3\Omega$		4.6		ns
开启上升时间 Turn -On Rise Time	T_r			13		
关断延迟 Turn -Off Delay Time	Td(off)			27		
关断下降时间 Turn -Off Fall Time	T_f			10		
栅极电荷 Total Gate Charge	Qg	$I_D =15A, V_{DS} = 15V$ $V_{GS} = 4.5V$		13		nC
栅源电荷 Gate-to-Source Charge	Qgs			4.2		nC
栅漏电荷 Gate-to-Drain Charge	Qgd			5.1		nC
二极管正向压降 Diode Forward Voltage	V_{SD}	$T_j=25^\circ C, I_s=10A$ $V_{GS} =0V$			1.3	V
反向恢复时间 Reverse Recovery Time	trr	$T_j=25^\circ C, I_s=10A$ $di/dt=100A/\mu s$		9.2		ns
反向恢复电荷 Reverse Recovery Charge	Qrr			2		nC

●热特性

●Thermal Characteristics

参数 PARAMETER	符号 SYMBOL	最小值 MIN	典型值 TYP	最大值 MAX	单位 UNIT
热阻结-壳 Thermal Resistance Junction-case	RthJC			2.72	°C/W

注释(Notes):

- ① 初始结温=25°C, L=0. 1mH。
Starting $T_j=25^\circ C, L=0. 1mH$ 。

N-沟道功率 MOS 管/ N-CHANNEL POWER MOSFET

SIF60N030

● 特性曲线



图 1 输出特性曲线

Fig.1 output characteristics

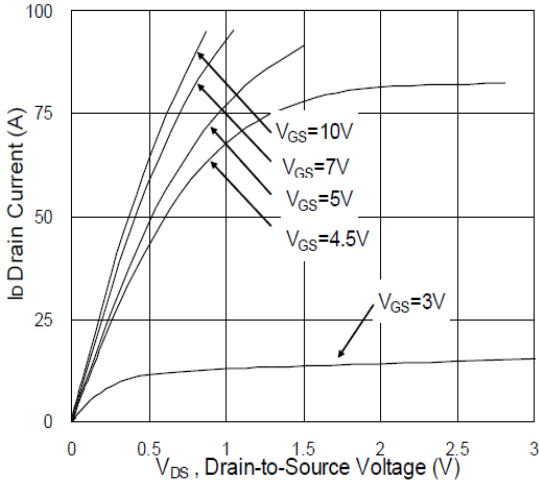

图 2 归一化导通电阻与结温关系曲线

Fig.2 Normalized RDSON vs. T_J

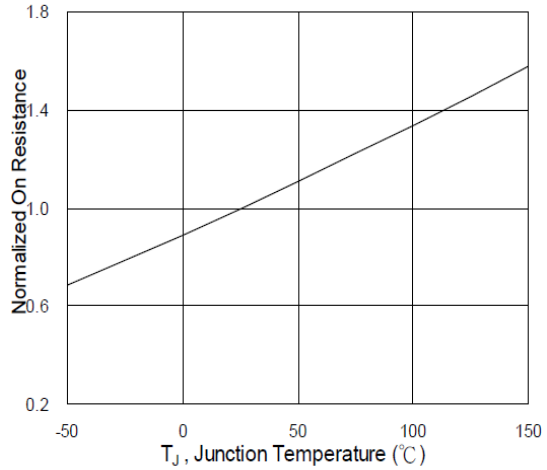

图 3 归一化开启电压与结温关系曲线

Fig.3 Normalized V_{th} vs. T_J

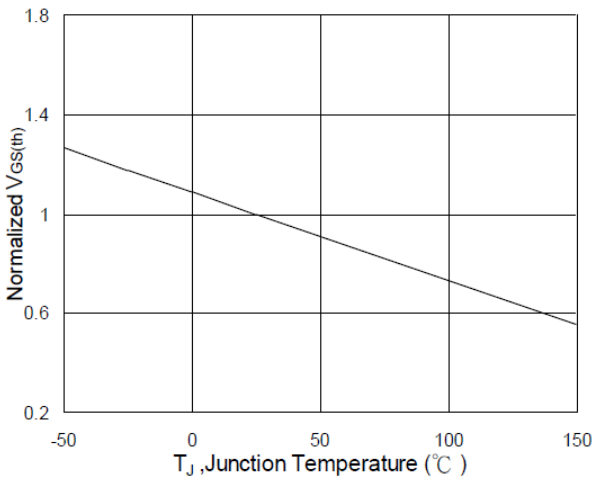

图 4 栅电荷波形

Fig.4 Gate Charge Waveform

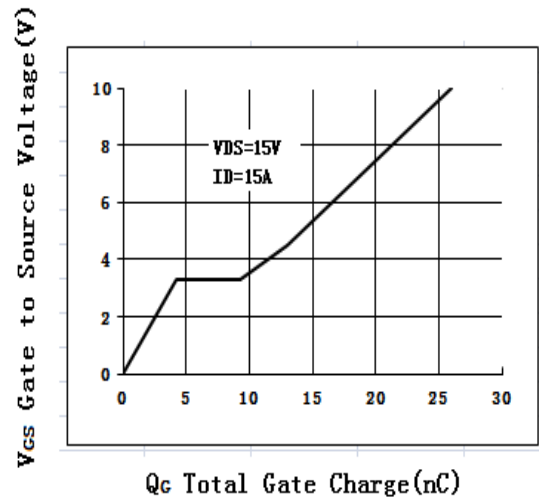

图 5 电容曲线

Fig.5 Capacitance

DFN3X3-8L 封装机械尺寸
DFN3X3-8L Package Information

DFN3*3 封装机械尺寸

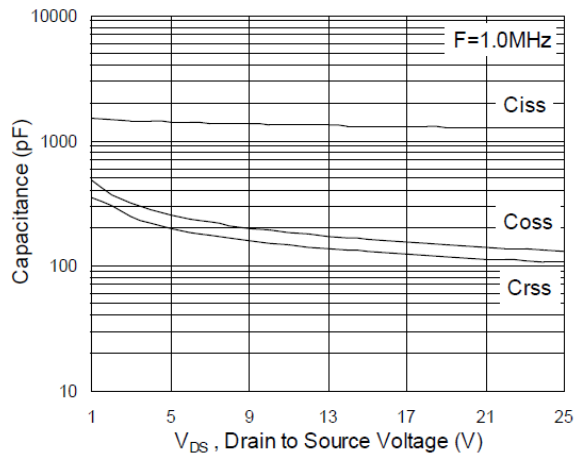
单位:毫米/UNIT: mm

符号 SYMBOL	最小值 min	典型值 nom	最大值 max	符号 SYMBOL	最小值 min	典型值 nom	最大值 max
A	0.70	0.75	0.80	b	0.25	0.30	0.35
c	0.10	0.15	0.25	D	3.25	3.35	3.45
E	3.20	3.30	3.40	D1	3.00	3.10	3.20
E1	3.00	3.15	3.20	D2	1.78	1.88	1.98
E2	2.39	2.49	2.59	D3	--	0.13	--
L	0.30	0.40	0.50	e	--	0.65	--
L1	--	0.13	--	H	0.30	0.39	0.50
M	--	--	0.15				

