

N-沟道功率 MOS 管/ N-CHANNEL POWER MOSFET

SIF8N100

- 特点：热阻低 导通电阻低 栅极电荷低，开关速度快 输入阻抗高 符合RoHS规范
- FEATURES: ■LOW THERMAL RESISTANCE ■LOW $R_{DS(ON)}$ TO MINIMIZE CONDUCTIVE LOSS ■LOW GATE CHARGE FOR FAST SWITCHING ■HIGH INPUT RESISTANCE ■RoHS COMPLIANT
- 应用：低压高频逆变电路 同步整流 开关应用
- APPLICATION: ■LOW VOLTAGE,HIGH FREQUENCY INVERTERS ■SYNCHRONOUS RECTIFICATION ■SWITCH APPLICATIONS

●最大额定值 (TC=25°C)

●Absolute Maximum Ratings (Tc=25°C)

SOP-8

参数 PARAMETER	符号 SYMBOL	额定值 VALUE	单位 UNIT
漏-源电压 Drain-source Voltage	V_{DS}	100	V
栅-源电压 gate-source Voltage	V_{GS}	± 20	V
漏极电流 Continuous Drain Current TC=25°C ①	I_D	8*	A
耗散功率 Total Power Dissipation ①	P_{tot}	2.6	W
最高结温 Junction Temperature	T_j	150	°C
存储温度 Storage Temperature	T_{STG}	-55-175	°C
单脉冲雪崩能量 Single Pulse Avalanche Energy ②	E_{AS}	88	mJ

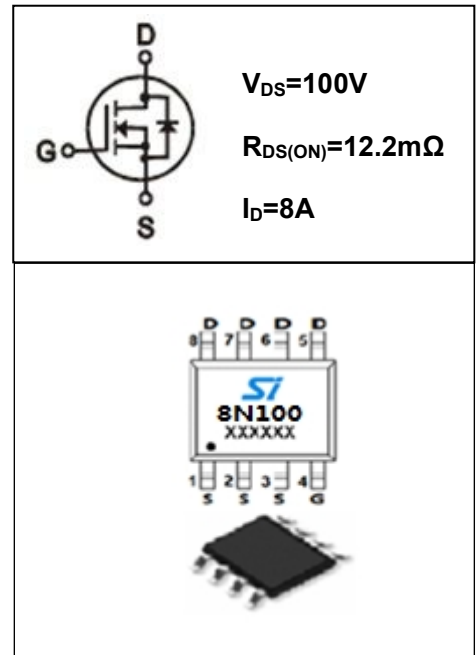

●电特性 (Tc=25°C)

●Electronic Characteristics (Tc=25°C)

参数 PARAMETER	符号 SYMBOL	测试条件 TEST CONDITION	最小值 MIN	典型值 TYP	最大值 MAX	单位 UNIT
漏-源击穿电压 Drain-source Breakdown Voltage	BV_{DSS}	$V_{GS}=0V, I_D=250\mu A$	100	108		V
栅极开启电压 Gate Threshold Voltage	$V_{GS(TH)}$	$V_{GS}=V_{DS}, I_D=250\mu A$ ③	1.4	1.85	2.5	V
漏-源漏电流 Drain-source Leakage Current	I_{DSS}	$V_{DS}=100V, V_{GS}=0V$			1	μA
栅极漏电流 Gate-body Leakage Current ($V_{DS}=0$)	I_{GSS}	$V_{GS}=\pm 20V$			±100	nA
漏-源导通电阻 Static Drain-source On Resistance	$R_{DS(ON)}$	$V_{GS}=10V, I_D=8A$ ③		12.2	16	mΩ
		$V_{GS}=4.5V, I_D=6A$ ③		13.2	17	
跨导 Forward Transconductance	g_{FS}	$V_{DS}=10V, I_D=8A$ ③	26			S

●订单信息/ORDERING INFORMATION:

包装形式/PACKING	订货编码/ORDERING CODE	
	普通塑封料/ Normal Package Material	无卤塑封料/Halogen Free
SOP-8 条管装/TUBE PACKING	SIF8N100 SOP-8-TU	SIF8N100 SOP-8-TU-HF
SOP-8 编带装/TAPE & REEL PACKING	SIF8N100 SOP-8-TR	SIF8N100 SOP-8-TR-HF

N-沟道功率 MOS 管/ N-CHANNEL POWER MOSFET

SIF8N100

参数 PARAMETER	符号 SYMBOL	测试条件 TEST CONDITION	最小值 MIN	典型值 TYP	最大值 MAX	单位 UNIT
输入电容 Input Capacitance	Ciss	$V_{GS} = 0V, V_{DS} = 20V$ $F = 1.0MHz$		3600		pF
输出电容 Output Capacitance	Coss			230		
反向传输电容 Reverse Transfer Capacitance	Crss			170		
导通延迟 Turn -On Delay Time	Td(on)			15		ns
开启上升时间 Turn -On Rise Time	T_r	$V_{DD}=30V, R_L=1\Omega$ $V_{GS} = 10V, R_{GEN}=3\Omega$		11		ns
关断延迟 Turn -Off Delay Time	Td(off)			52		ns
关断下降时间 Turn -Off Fall Time	T_f			13		ns
栅极电荷 Total Gate Charge	Qg			94		nC
栅源电荷 Gate-to-Source Charge	Qgs	$I_D = 8A, V_{DS} = 30V$ $V_{GS} = 10V$		16		nC
栅漏电荷 Gate-to-Drain Charge	Qgd			24		nC
二极管正向压降 Diode Forward Voltage	V_{SD}	$T_j=25^\circ C, I_F=8A$ $V_{GS}=0V$ ③		0.76	1.3	V
反向恢复时间 Reverse Recovery Time	trr	$I_f=8A, di/dt=100A/\mu s$		33		ns
反向恢复电荷 Reverse Recovery Charge	Qrr	$T_j=25^\circ C$, ③		54		nC

●热特性

● Thermal Characteristics

参数 PARAMETER	符号 SYMBOL	最大值 MAX	单位 UNIT
热阻结-壳 Thermal Resistance Junction-case	RthJA	48	$^\circ C/W$

注释(Notes):

- ① 以最高结温为限制， $T_c=25^\circ C$ 时测试。
 I_D & P_D base on maximum allowable junction temperature, test at $T_c=25^\circ C$.
- ② 初始结温= $25^\circ C$, $L=0.1mH$.
Starting $T_j=25^\circ C, L=0.1mH$
- ③ 脉冲测试: 脉冲宽度 $\leq 300\mu s$, 占空比 $\leq 2\%$
Pulse Test : Pulse width $\leq 300\mu s$, Duty cycle $\leq 2\%$

N-沟道功率 MOS 管/ N-CHANNEL POWER MOSFET

SIF8N100

● 特性曲线

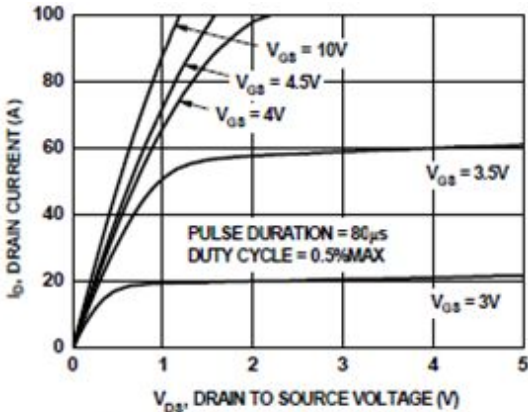

Figure 1 Output Characteristics

图 1 输出特性曲线, Tc=25°C

Fig1 Typical Output Characteristics, Tc=25°C

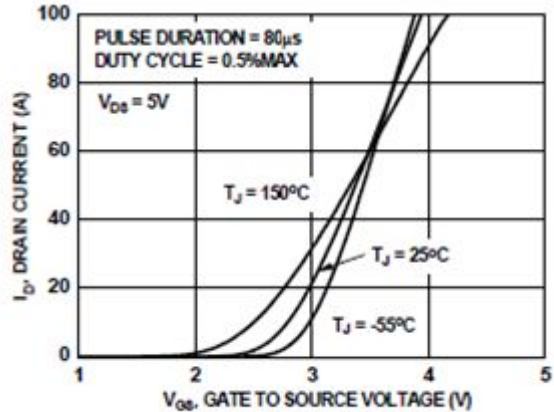

Figure 2 Transfer Characteristics

图 2 转移特性曲线

Fig2 Resistance V.S Drain Current

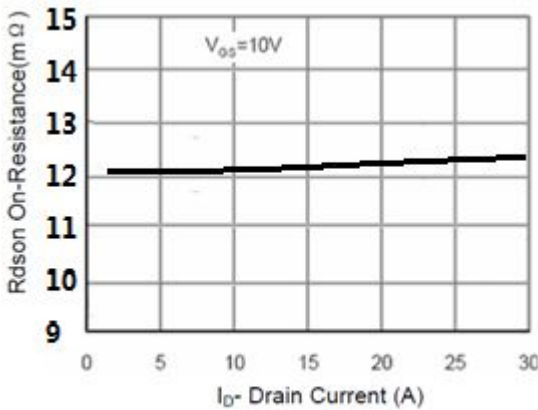

Figure 3 Rdson- Drain Current

图 3 导通电阻与漏极电流的曲线

Fig3 Threshold Voltage V.S Junction Temperature

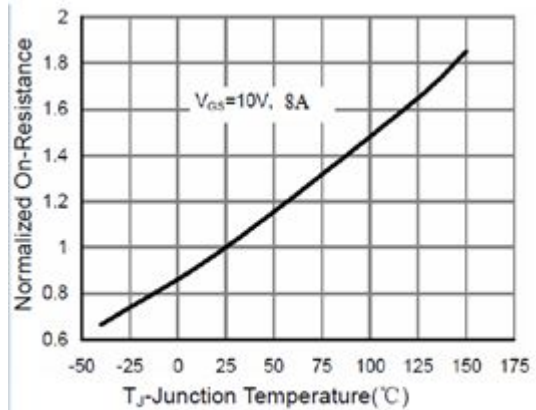

Figure 4 Rdson-JunctionTemperature

图 4 导通电阻与结温度曲线

Fig4 Resistance V.S Junction Temperature

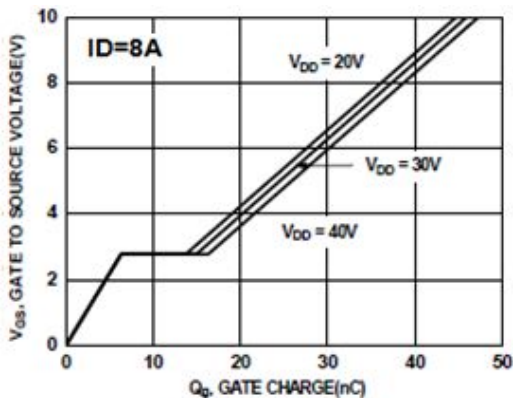

Figure 5 Gate Charge

图 5 典型栅极电荷与栅源电压曲线

Fig5 Typical Gate Charge V.S Gate-to-Source Voltage

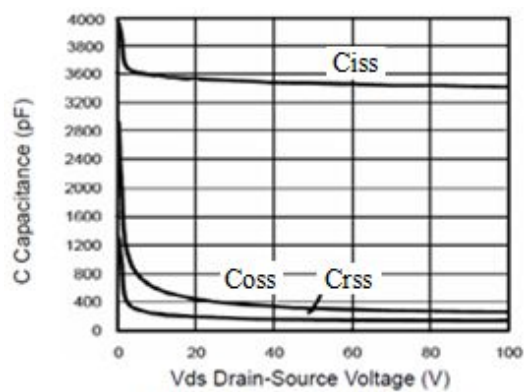

Figure 6 Capacitance vs Vds

图 6.典型电容与漏源电压的曲线

Fig6 Typical Capacitance V.S Drain-to-Source Voltage

SOP8 封装机械尺寸 SOP8 MECHANICAL DATA

单位:毫米/UNIT: mm

符号 SYMBOL	最小值 min	典型值 nom	最大值 max	符号 SYMBOL	最小值 min	典型值 nom	最大值 max
A	4.80		5.10	C	1.30		1.50
A1	0.37		0.47	C1	0.55		0.75
A2		1.27 TYP		C2	0.55		0.65
A3		0.41 TYP		C3	0.05		0.20
B	5.80		6.20	C4	0.19	0.20TYP	0.23
B1	3.80		4.00	D		1.05TYP	
B2		5.0TYP		D1	0.40		0.62

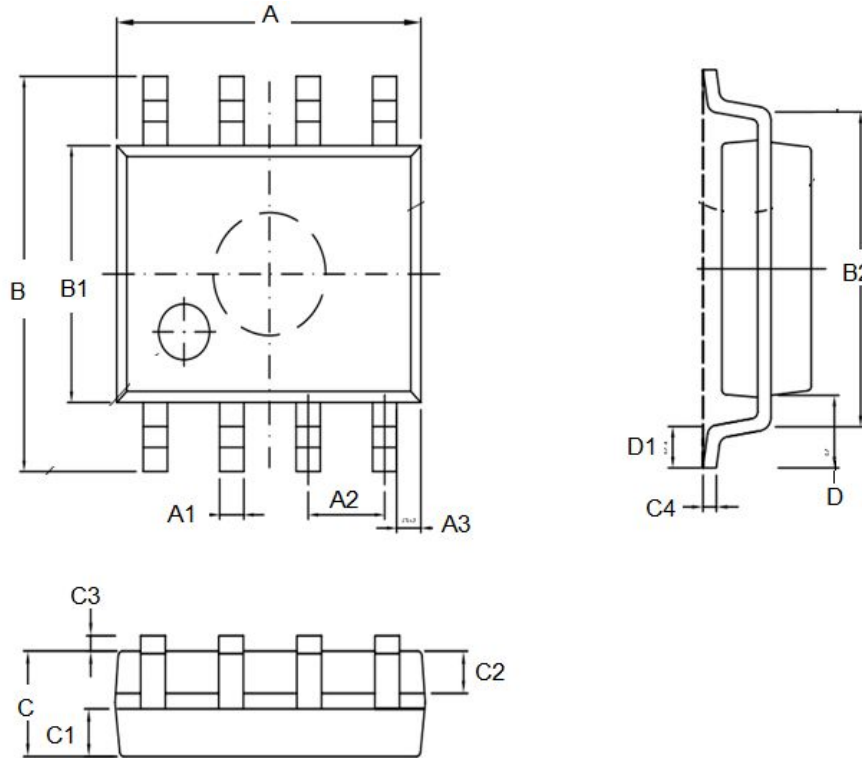

SOP8 (13")编带规格 SOP8 (13")TAPE AND REEL DATA

单位:毫米/UNIT: mm

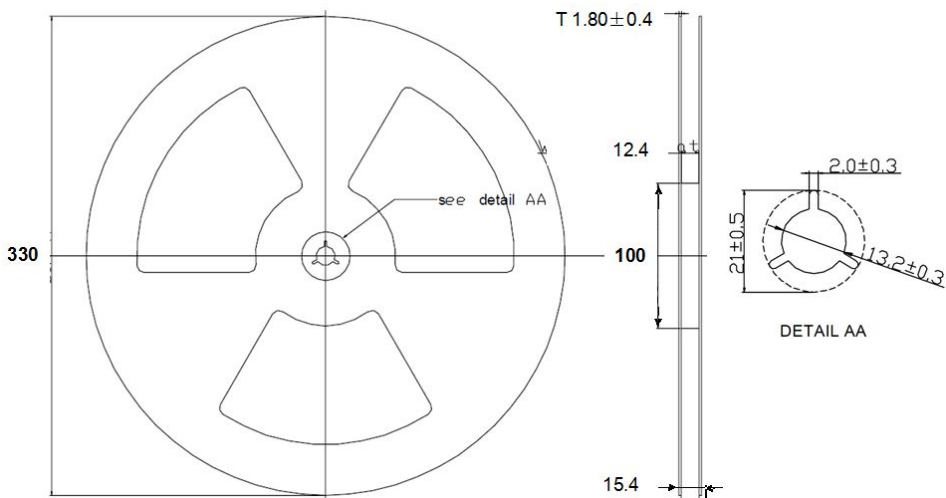
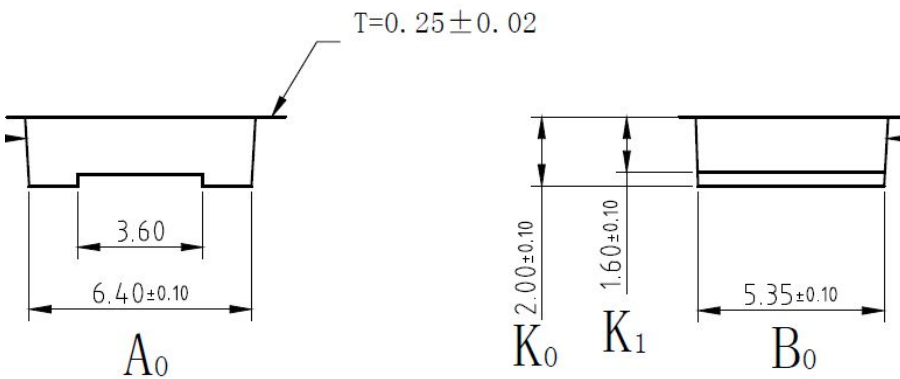
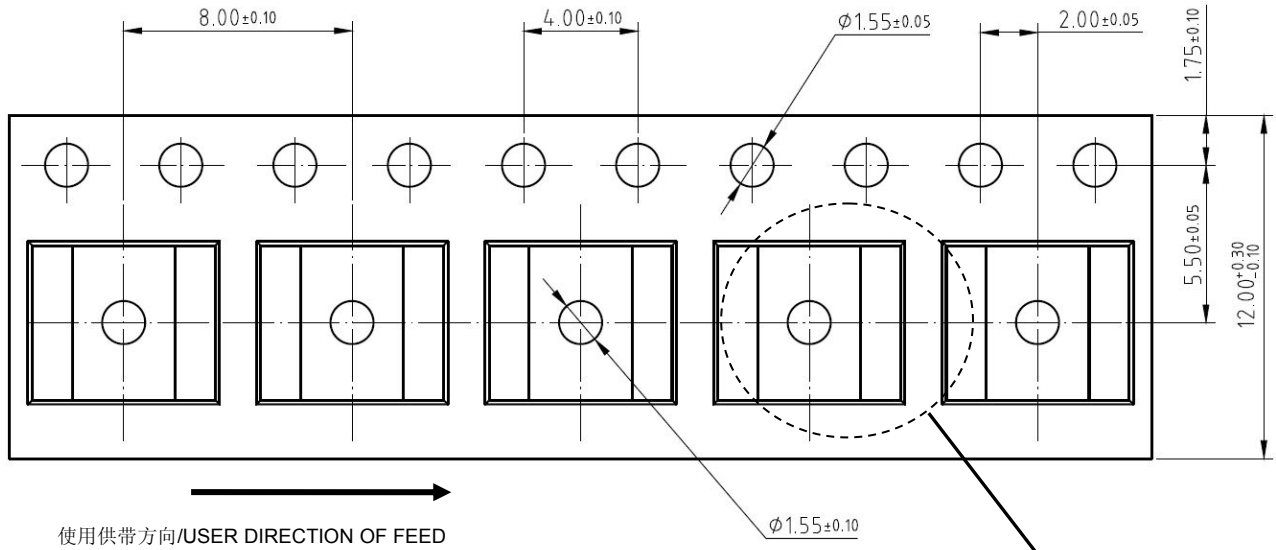

13"卷盘/REEL